

# CANTED COPING

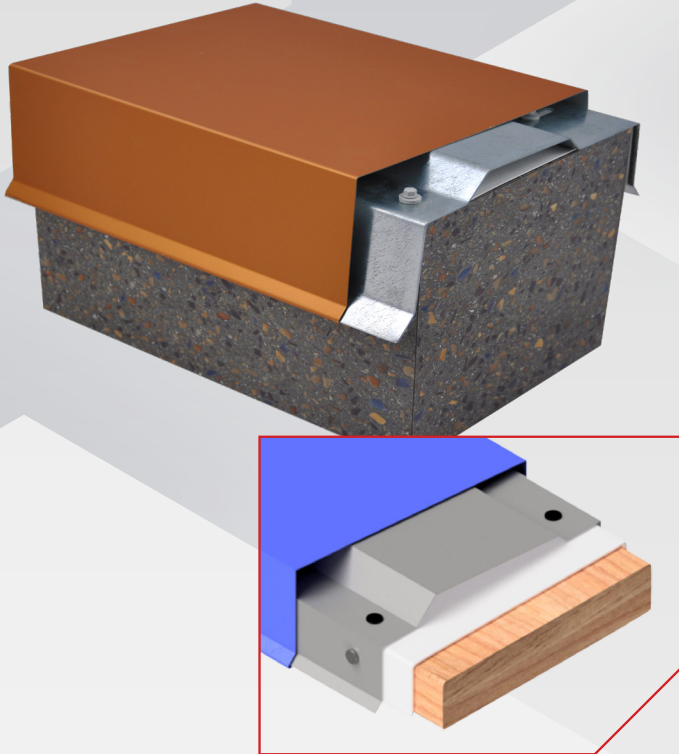

## PRODUCT DESCRIPTION

Elevate Canted Coping system offers a streamlined installation with its full snap-on design and concealed fasteners, providing a clean, professional finish for any parapet wall, and allows for easy thermal movement. Compliant with ANSI/SPRI/FM4435/ES-1 and FM approved, this system ensures durability and long-term performance.

## FEATURES

- Available in 10-foot lengths and customized widths to fit various parapet walls.
- The system includes 16-gauge galvanized steel cleats spaced at 60 inches, eliminating the need for crimping.
- 6-inch concealed splice plate eliminates exposed fasteners.
- Riveted inside and outside miters and end caps are available.
- Size ranges available: Face 4" to 10", wall 8" to 30", and back 3" to 6".

## CODES & STANDARDS



ANSI/SPRI/FM4435/ES-1

MATERIAL	THICKNESS	FINISH
Aluminum	0.040 in.	Mill or PVDF
Stainless Steel	24 gauge	N/A
Bonderized Steel	24 gauge	N/A
Galvalume®	24 gauge	Mill or PVDF

## INSTALLATION

- 1] A wood nailer is required on top of the parapet wall. The wood nailer should be attached in accordance with ANSI/SPRI/FM4435/ES-1.
- 2] Install in accordance with Elevate Detail 6054.
- 3] For any deviation from the requirements set forth in detail drawings, please contact your Regional Technical Coordinator at (800) 428-4511.

Talk to your Elevate rep or visit [HolcimElevate.com](https://HolcimElevate.com) to learn more.



FIND YOUR REP